

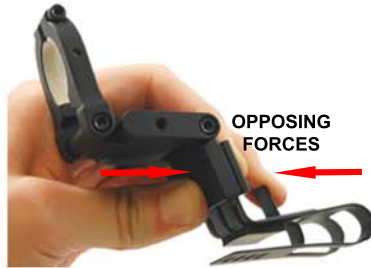

INSTALLATION INSTRUCTIONS FOR BELTRONICS AND ESCORT RADAR DETECTORS



1 - Install your radar detector (RD) onto the mount before installing it on the rear view mirror. To release tension from the spring clip, simply squeeze the release tab and the back side of the mount together. This will lower the bottom portion of the spring clip allowing you to slide the RD on and off the mount.



2 - Push the RD release button when installing and removing the RD onto the spring clip. Slide the clip into the RD as far as possible until you hear it lock into position. Remove the RD a few times so you can observe how the spring clip functions. When used properly, the spring clip avoids putting excessive pressure on the mirror stem when installing and removing the RD.

Grab the mirror and move the stem upward using the windshield pivot only

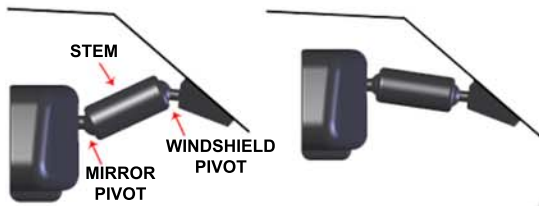

3 - Most compatible mirrors have a stem between the mirror and the windshield that has a pivot on both ends. We recommend that you try moving the mirror upward before installing the mount. Grab the mirror and move the stem upward using the windshield pivot only. Adjust the mirror to your normal viewing position using the mirror pivot only. Notice the higher location of the mirror as shown above. **NOTE: The mirror stem may move side to side as well.**

Make sure the stem points straight ahead so the radar RD does too.

Mirror stem can pivot left/right to point radar detector where desired

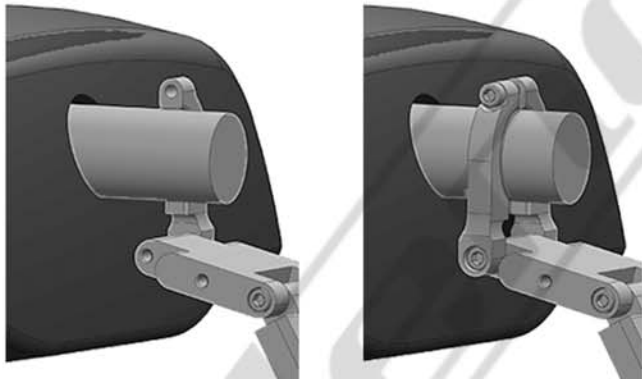

4 - Install the mount while sitting in the passenger side of your vehicle. Remove the right-top portion of the mount and position the mount around the mirror stem as shown above. Reattach the right side of the mount. Make sure the lock washer is still on the lower clamp screw. Leave the top screw loose so the mount can slide along the mirror stem and rotate to the desired location. There may be a plastic oval clip around a wire and the stem, the clip must be removed to install the mount. **Lightly snug screws, do not fully tighten until last step.**

BLENDMOUNT CENTER LINK

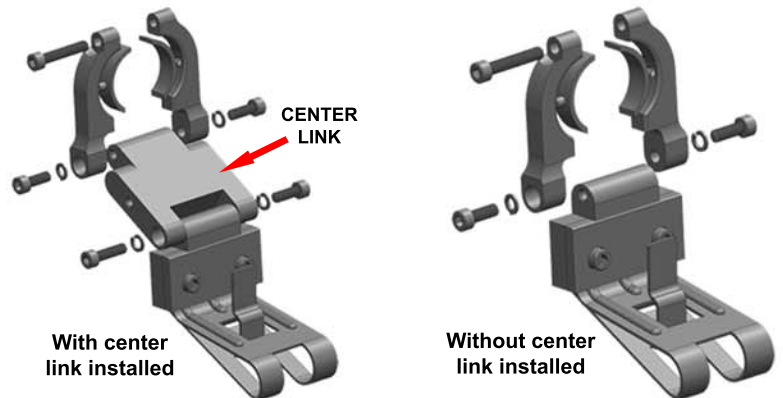

5 - The center-link may be removed if an overall shorter mount length is needed, depending on your rear view mirror and desired position for the radar detector.



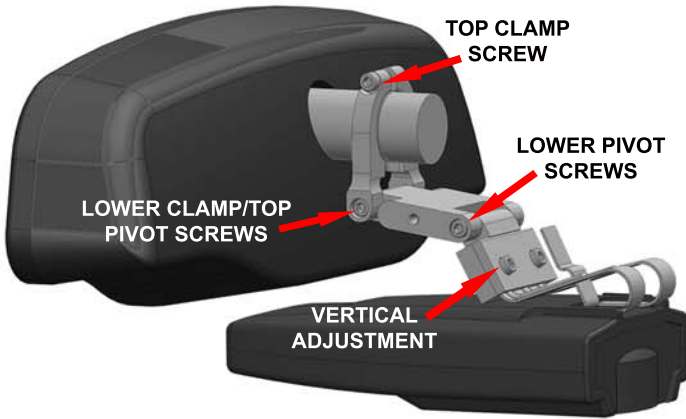

7 - Install the RD onto the mount. Make the necessary adjustments as shown above. Using the vertical adjustment, we recommend you adjust the RD as close to the bottom of the mirror as possible. The spring clip holding the RD is designed to flex downward to allow access to the RD buttons as shown below in step 9.

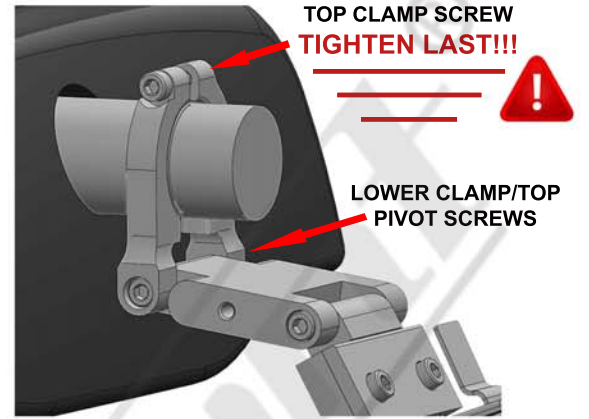

8 - At this point your RD should be positioned where you want it and the screws should be snug. Loosen the top clamp screw so both the lower clamp/top pivot screws can be fully tightened. Grab the long arm of the allen wrench to assure that these screws are securely tightened, you will not strip out the tapped holes in the aircraft grade aluminum. **The bottom clamp screws should be fully tightened before tightening the top clamp screw. If the top screw is tightened before the bottom screws are, the clamp will loosen over time.**



9 - To access the buttons of the RD you will need to gently push downward on the front of the RD with one finger and push the desired button with another finger. Then allow the RD to return to it's original position by gently letting it spring upward. When accessing the buttons, be sure to push the RD downward just enough for your finger to fit between the RD and mirror. **Do not push down more than what is needed.**



NOTE : This mount can get extremely hot when sitting in direct sunlight. If you intend to remove your RD frequently, you may want to install the two gray "TOUCH STRIPS" included in the tool kit. Place them where your fingers make contact with the mount. They may be trimmed with a blade or knife.

FOR MORE INFO VISIT www.blendmount.com/videos

CAUTION

DO NOT use this mount if it interferes with the adjustability or the operation of your rear view mirror in any way.

DO NOT use this mount if the radar detector creates an unsafe viewing obstruction.

DO NOT ATTEMPT TO MODIFY THIS PRODUCT. Consult the manufacturer for assistance.

All BlendMount products are accompanied with detailed installation instructions and adjustment tips. You are encouraged to contact customerservice@blendmount.com or call J28 Design at 1-888-497-8388 for further assistance.

Check the BlendMount Forum for installation tips and some vehicle specific installs. www.blendmount.com

Your feedback is very important to us. Please email any questions or comments you have to customerservice@blendmount.com